

INSTRUMENT

Quick Connectors



Features

- It was designed to flow in both directions.
- Coupling and uncoupling enables quick, easy operation.
- Simply push and pull the line can be connected and disconnected.
- No tools needed was a compact and lightweight design.
- There are two kinds of stems.
- Single type stems have no valve.
- Double type stem have valve.

Operation

- When coupling and uncoupling, Should not be used to exceed the pressure of 250 psi (17.2 bar).
- Coupling
Placed on the stem and the body straight. Connect by inserting the stem in the body.
- Uncoupling
Pull the body sleeve to the stem direction. Remove the stem inserted in the body.

Materials of Construction

BODY

No.	Description	Materials
1	BODY	316SS
2	BODY POPPET	316SS
3	BODY INSERT	316SS
4	HOUSING	316SS
5	BODY SLEEVE	316SS
6	C-RING	304SS
7	SPRING	304SS
8	LOCKING DOGS	316SS Powdered metal
9	O-RING	FKM
10	O-RING	FKM
11	O-RING	FKM
12	SPRING	304SS

STEM

No.	Description	Materials
13	STEM	316SS
14	STEM SLEEVE	316SS
15	STEM VALVE	316SS
16	SPRING	304SS
17	O-RING	FKM
18	SPRING	304SS
19	VALVE INSERT	316SS
20	NUT	316SS
21	BACK FERRULE	316SS
22	FRONT FERRULE	316SS

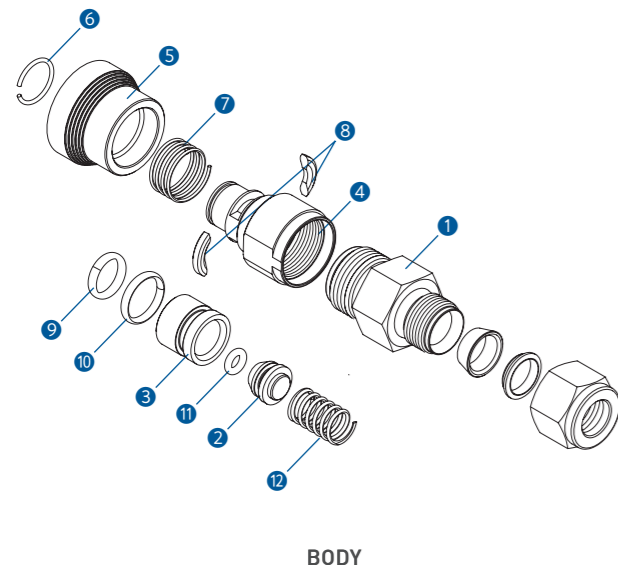

BODY

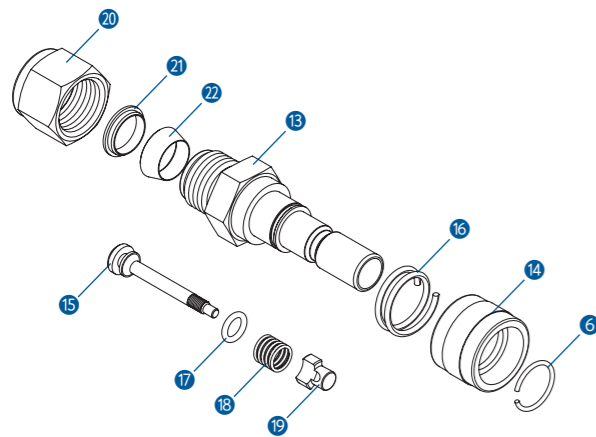

STEM

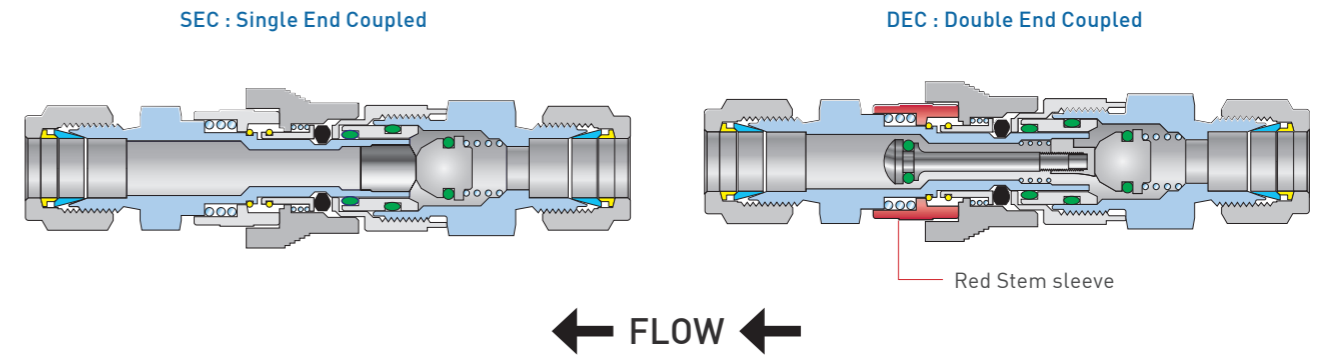

Pressure-Temperature Ratings

UQ Stem and Body	316SS FKM O-rings			Brass NBR O-rings		
	UQ1	UQ2	UQ3	UQ1	UQ2	UQ3
	psi (bar) @ °F (°C)					
Coupled	3000 (206) @70 (21)	1500 (103) @70 (21)	750 (51.6) @70 (21)	2000 (137) @70 (21)	1000 (68.9) @70 (21)	500 (34.4) @70 (21)
Uncoupled	250 (17.2)@400 (204)			250 (17.2)@250 (121)		
When coupling and uncoupling	250 (17.2) @ 70 (21) Do not couple or uncouple at pressures exceeding 250 psig (17.2 bar).					

Spillage and Air Inclusion

UQ Series	Spillage (cm³)	Air Inclusion (cm³)
UQ1	0.3	0.3
UQ2	1.0	1.0
UQ3	3.0	3.0

- Spillage is the volume of system fluid that escapes while a quick connector is uncoupled. (Only double)
- Air inclusion is the volume of air trapped that comes in while a quick connector is coupled. (Only double)

Insertion depth

UQ Series	Depth mm (in)	
	SEC	DEC
UQ1	27.7(1.09)	29.2(1.15)
UQ2	30.0(1.18)	33.0(1.30)
UQ3	37.6(1.48)	42.7(1.68)

Insertion depth and Overall Length

- To obtain a combined length and add the length of the body and stem, subtract the insertion depth.

Cleaning

UNILOK quick connectors are free machine oil, loose particles and grease throughout the close cleaning process.

Testing

Every UQ series quick connector is 100% factory tested for proper functionality.

How To order

UNILOK UQ series Quick Connectors are ordered by part number as shown below.

Example: The following part number, *UQB3U-08T-SS* is designated for UQB3 series Quick Connector with both 1/2" UNILOK tube fitting, 316SS.



Valve Type		
Body	Body	QB
Stem	Single	QS
	Double	QD
Set	Single	QBS
	Double	QBD
Bulkhead-Body	Bulkhead-Body	BQB
Bulkhead -Stem	Single	BQS
	Double	BQD
Bulkhead -Set	Single	BQBS
	Double	BQBD

Connection Type	
U	UNILOK Tube Fitting
F	Female NPT or ISO7/1(PT)
M	Male NPT or ISO7/1(PT)

Important Notification

Proper installation, materials compatibility, operation and maintenance of these valves are the responsibility of the user. The total system design must be taken into consideration to ensure optimal Performance and safety.

Do not couple or uncouple at pressures exceeding 250 psig (17.2 bar).

Prohibit the together use with quick connectors of other companies.

Connection Size					
Fractional(Inch) Tube O.D. Designation					
Tube O.D.	inch	1/8	1/4	3/8	1/2
	mm	3.17	6.35	9.52	12.7
Designator		02T	04T	06T	08T

Metric Tube O.D. Designation				
Tube O.D.	mm	6	10	12
Designator		M06T	M10T	M12T

Pipe Size Designation (NPT or ISO7/1-PT)			
Pipe Size	1/4	3/8	1/2
Designator	04N/R	06N/R	08N/R

Body Materials	
SS	316SS
BS	Brass

Ordering Information & Dimensions Stems

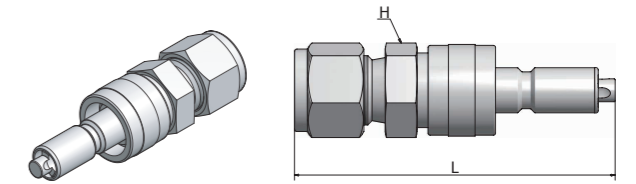

SEC : There's no a valve in the stem.
DEC: There's a valve in the stem.

Part Number Series (* = S or D)	End Connection	Cv			Dimensions (mm)					
		Inlet	Outlet	SEC	DEC	Full Flow	L		H	
							SEC	DEC	inch	mm
UQ*1	U-02T-	1/8" UNILOK		0.08	0.08	0.08	58.9	70.4	5/8	15.87
	U-04T-	1/4" UNILOK		0.3	0.2	0.4	59.9	61.5	5/8	15.87
	U-M06T-	6 mm UNILOK		0.3	0.2	0.4	59.9	61.5	5/8	15.87
	M-02N-	1/8" Male NPT		0.3	0.2	0.4	52.6	54.1	5/8	15.87
	M-04N-	1/4" Male NPT		0.3	0.2	0.4	56.4	57.9	5/8	15.87
	F-02N-	1/8" Female NPT		0.3	0.2	0.4	51.1	52.6	5/8	15.87
	F-04N-	1/4" Female NPT		0.3	0.2	0.4	57.4	58.9	3/4	19.05
UQ*2	U-06T-	3/8" UNILOK		1.0	0.5	1.5	64.0	67.1	3/4	19.05
	U-M10T-	10 mm UNILOK		1.0	0.5	1.5	67.3	70.4	3/4	19.05
	M-04N-	1/4" Male NPT		0.9	0.5	1.5	58.9	61.9	3/4	19.05
	M-06N-	3/8" Male NPT		0.8	0.5	1.6	59.7	62.7	3/4	19.05
	F-04N-	1/4" Female NPT		0.9	0.5	1.5	59.7	62.7	3/4	19.05
	F-06N-	3/8" Female NPT		0.8	0.5	1.6	59.7	62.7	7/8	22.22
	UQ*3	U-08T-	1/2" UNILOK		2.4	1.5	3.3	75.2	80.3	15/16
U-M12T-		12mm UNILOK		2.4	1.5	3.3	75.2	80.3	15/16	23.81
M-08N-		1/2" Male NPT		2.0	1.3	3.1	72.1	77.2	15/16	23.81
F-08N-		1/2" Female NPT		2.0	1.3	3.1	71.6	76.7	15/16	23.81

NPT threads are available for all STEM. To order, add "R" as a suffix instead of "N"

Dimensions are for reference only and are subject to change without prior notice.

Ordering Information & Dimensions Bodies

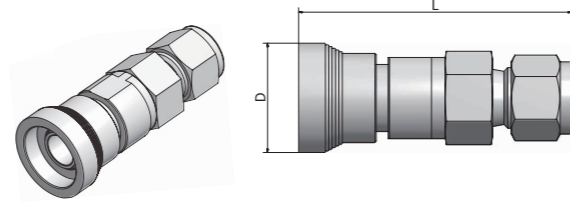

Part Number	End Connection		Dimensions (mm)	
	Inlet	Outlet	L	D
UQ*1	U-02T-	1/8" UNILOK	57.4	23.1
	U-04T-	1/4" UNILOK	56.4	23.1
	U-M06T-	6mm UNILOK	58.4	23.1
	M-02N-	1/8" Male NPT	51.1	23.1
	M-04N-	1/4" Male NPT	54.9	23.1
	F-02N-	1/8" Female NPT	54.9	23.1
	F-04N-	1/4" Female NPT	61.5	23.1
UQ*2	U-06T-	3/8" UNILOK	65.5	26.2
	U-M10T-	10mm UNILOK	68.1	26.2
	M-04N-	1/4" Male NPT	60.5	26.2
	M-06N-	3/8" Male NPT	60.5	26.2
	F-04N-	1/4" Female NPT	64.5	26.2
	F-06N-	3/8" Female NPT	65.3	26.2
	UQ*3	U-08T-	1/2" UNILOK	78.5
U-M12T-		12mm UNILOK	78.5	30.7
M-08N-		1/2" Male NPT	75.4	30.7
F-08N-		1/2" Female NPT	81.8	30.7

NPT threads are available for all BODY. To order, add "R" as a suffix instead of "N"

Dimensions are for reference only and are subject to change without prior notice.

Ordering Information & Dimensions Stems-Bulkhead

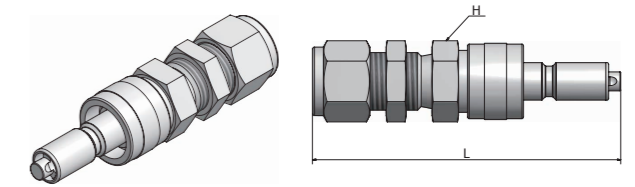

SEC : There's no a valve in the stem.
DEC: There's a valve in the stem.

Part Number Series (* = S or D)	End Connection		Dimensions (mm)					
	Inlet	Outlet	Panel Thickness Max.	Panel Hole Dia Min.	L		H	
					SEC	DEC	inch	mm
UBQ*1	U-04T-	1/4" UNILOK	6.4	11.9	69.6	71.1	5/8	15.88
	U-M06T-	6mm UNILOK	6.4	11.5	69.6	71.1	11/16	17.46
UBQ*2	U-06T-	3/8" UNILOK	6.9	15.1	74.2	76.0	3/4	19.05
	U-M10T-	10mm UNILOK	6.9	16.7	77.7	78.7	7/8	22.22
UBQ*3	U-08T-	1/2" UNILOK	6.6	19.8	87.1	92.2	15/16	23.81
	U-M12T-	12mm UNILOK	6.6	19.4	87.1	92.2	1	25.40

Ordering Information & Dimensions Bodies-Bulkhead

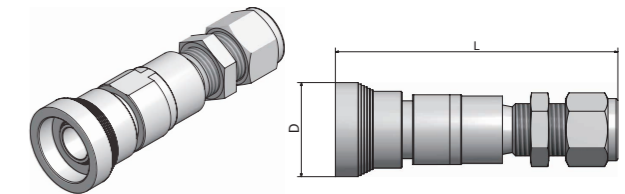

Part Number	End Connection		Dimensions (mm)			
	Inlet	Outlet	Panel Thickness Max.	Panel Hole Dia Min.	L	D
UBQB1	U-04T-	1/4" UNILOK	6.4	11.9	67.8	23.1
	U-M06T-	6mm UNILOK	6.4	11.9	67.8	23.1
UBQB2	U-06T-	3/8" UNILOK	6.9	15.1	75.7	26.2
	U-M10T-	10mm UNILOK	6.9	16.7	75.9	26.2
UBQB3	U-08T-	1/2" UNILOK	6.6	19.8	90.4	30.7
	U-M12T-	12mm UNILOK	6.6	19.4	90.4	30.7

Dimensions are for reference only and are subject to change without prior notice

Stem and Body Protectors

Features

- The protectors protect the uncoupling body and stem from contaminants and damage.
- Protectors are not a device for maintaining the pressure.

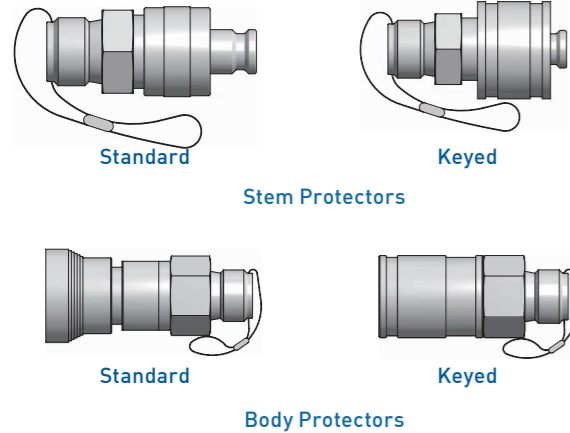

Materials

Component	Materials
Protector	316SS or Brass
Lanyard	316SS
Lanyard clamps	316SS

How to order

Series	Part Number		* = Materials
	Basic Ordering Numbers		
	Stem Protector	Body Protector	
UQ1	SP-*	BP-*	316SS=SS Brass=BS
UQ2			
UQ3			

Protectors

Example: UQ1SP-SS

Keyed Protectors

Add a key number from the table under table to the key number.

Example: UQ1SP-SS-KB

UQ color coded “Keyed” Quick Connectorst

Features

- UQ Keyed quick connectors provide a positive mechanical lockout system.
- A product to prevent the connection lines of different systems.
- This is useful when many lines in the system.

Ordering Information & Dimensions

Key Number	Key Color	UQ1				UQ2				UQ3			
		Body Sleeve		Stem Sleeve		Body Sleeve		Stem Sleeve		Body Sleeve		Stem Sleeve	
		inch	mm	inch	mm	inch	mm	inch	mm	inch	mm	inch	mm
KB	Black	0.96	24.5	0.82	20.9	1.13	28.7	0.99	25.1	1.26	32.0	1.10	27.9
KO	Orange	0.99	25.0	0.85	21.6	1.16	29.5	1.02	25.8	1.29	32.8	1.14	28.9
KG	Green	1.02	26.0	0.88	22.4	1.19	30.2	1.05	26.6	1.32	33.6	1.17	29.7
KY	Yellow	1.05	26.8	0.91	23.2	1.22	31.0	1.08	27.4	1.35	34.3	1.20	30.4
KS	Blue	1.08	27.5	0.94	23.9	1.24	31.5	1.11	28.1	1.38	35.1	1.23	31.2
KW	White	1.11	28.3	0.97	24.7	1.28	32.5	1.14	28.9	1.41	35.8	1.26	32.0
KP	Purple	1.14	29.1	1.00	25.4	1.31	33.3	1.17	29.7	1.44	36.6	1.29	32.7
KN	Brown	1.17	29.8	1.03	26.2	1.34	34.0	1.20	30.4	1.47	37.4	1.32	33.5
Standard UQ Body Sleeve Dia.		0.91	23.1			1.03	26.2			1.21	30.7		

Dimensions are for reference only and are subject to change without prior notice.