

# FR-10 Series

## For Cylinder Single-Stage Pressure Regulator

### Specifications

Inlet Pressure Gauge	25MPa	Outlet Connection	Hose Nipple 8.5mm
Inlet Pressure	14.8MPa or less	Accessories	Gasket Packing(Fiber)×2Pcs.
Outlet Pressure	0.15 or 0.2MPa	Approximate Weight	1.2kg
Inlet Connection	W22-14 O.R.		



### Outline drawing

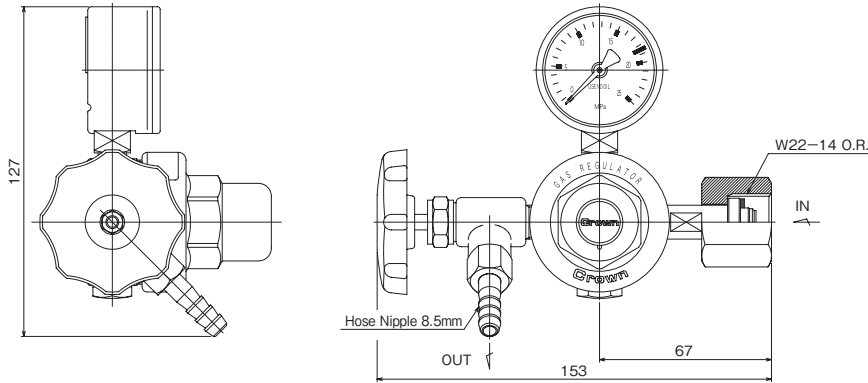

[Note]  
 ■ Unit: mm  
 ■ Dimensions are subject to change without notice.

### Flow characteristics

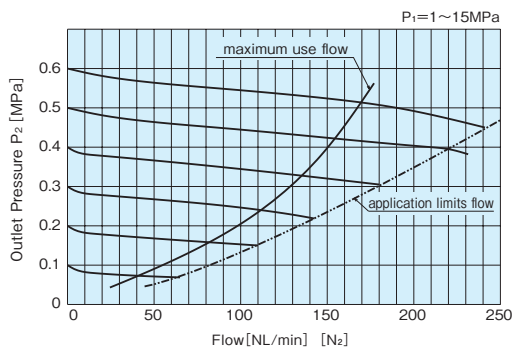

[Note]  
 ■ These tests were performed at ambient conditions.

### Materials of construction

Body	C3604 BD
Bonnet	ZDC
Poppet	C3604 BD
Seat	NBR
Diaphragm	NBR
Safety valve seat	NBR

### List of specifications

Series	Inlet Pressure Gauge MPa	Outlet Pressure MPa	Inlet Connection	Outlet Connection
FR-10	25	0.15	W22 (R)	Hose Nipple 8.5 mm
	25	0.2	W22 (R)	Hose Nipple 8.5 mm
	25	0.25	W22 (R)	Hose Nipple 8.5 mm
	25	0.15	W21 (L)	Hose Nipple 8.5 mm
	25	0.2	W21 (L)	Hose Nipple 8.5 mm
	25	0.25	W21 (L)	Hose Nipple 8.5 mm